



PS 200/2000.R2 Precision Balance

More information on the website  
[radwag.com/en/info,w1,NTZ](http://radwag.com/en/info,w1,NTZ)



PS 200/2000.R2 Precision Balance

The drawings, photos and graphics used are for illustrative purposes only.

## Functions



Autotest



Dosing



Percent Weighing



Totalizing



Parts counting



Peak hold



Newton unit  
measurement



Statistics



Checkweighing



GLP Procedures



Animal weighing



Density determination

# Datasheet

	PS 200/2000.R2 Precision Balance
<b>Metrological parameters</b>	
Maximum capacity [Max]	200 / 2000 g
Minimum load	20 mg
Readability [d]	1 / 10 mg
Verification unit [e]	10 / 100 mg
Tare range	-2000 g
Standard repeatability [5% Max]	0,5 / 5 mg
Standard repeatability [Max]	1 / 10 mg
Standard minimum weight (USP)	1 g
Standard minimum weight (U=1%, k=2)	0,1 g
Linearity	±2 / 20 mg
Stabilization time	2 / 1,5 s
Adjustment	internal (automatic)
OIML Class	II
<b>Physical parameters</b>	
Leveling system	manual
Display	LCD (backlit)
Delivery components	Balance, weighing pan, weighing pan shield, grounding bumper ×1, bumper ×3, power supply.
Weighing pan dimensions	128×128 mm
Packaging dimensions	475×380×345 mm
Net weight	3,9 kg
Gross weight	6 kg
<b>Construction</b>	
Protection class	IP 43
<b>Communication interface</b>	
Communication interface	2×RS232 <sup>1</sup> , USB-A, USB-B, Wi-Fi (option)
<b>Electrical parameters</b>	
Power supply	Adapter: 100 – 240V AC 50/60Hz 0,6A; 12V DC 1,2A Balance: 12 – 15V DC 0,4A max
Power consumption	4 W
<b>Environmental conditions</b>	
Operating temperature	+10 ÷ +40 °C

Repeatability is expressed as a standard deviation from 10 weighing cycles. Stabilization time depends on the ambient conditions and the dynamics of weighing pan loading; specified for FAST profile. 1 Barcode scanners, available as weighing instrument accessory, communicate with the instrument via RS232 interface exclusively.

\* Wi-Fi® is a registered trademark of Wi-Fi® Alliance.



Extra payment for verification



## Accessories

Balance Storage Case  
Antivibration Tables  
Power Adapters  
Cigarette lighter receptacle power supply cables

RS 232, RS 485 cables  
Displays  
Receipt Printer  
Protective cover for balances

USB cable (scale - printer)  
 Density determination KIT  
 Barcode scanners  
 Anti-Draft Chamber for Balances with a 128×128 mm Weighing Pan

RS 232, RS 485 cables  
 Under-pan weighing  
 RS 232 cables (scale - printer)

## Software

RAD-KEY  
 Alibi Reader  
 RADWAG Development Studio

R Panel  
 R-LAB

## Device dimensions

PS 200/2000.R2 Precision Balance

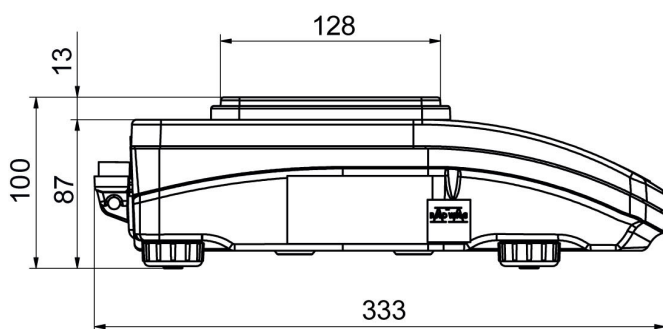

PS R, d = 1mg

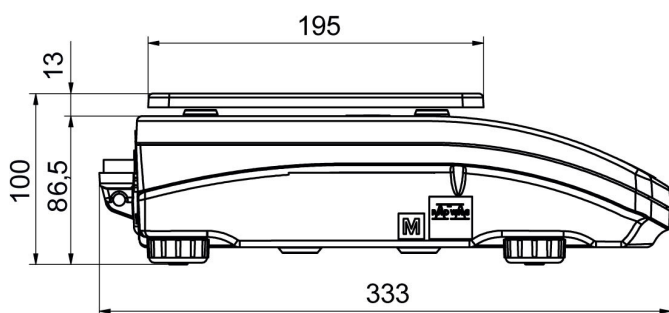
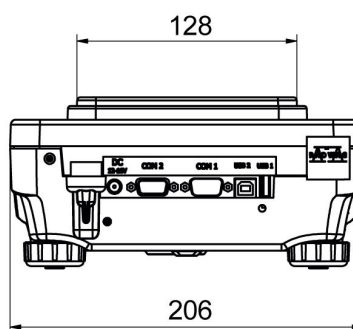

PS R, d = 10 mg

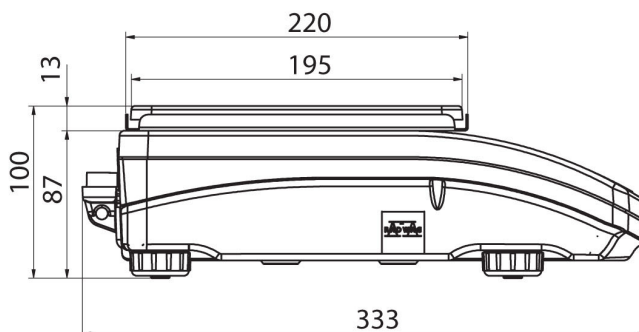
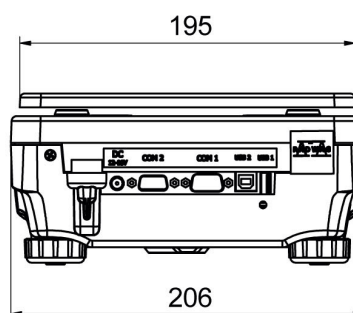

PS R.M, d = 10 mg

