

07/2018

# **Mod: ICE155WS-R2**

**Production code: GB1555W HC**



**Diamond**  
catering equipment



**Self-contained ice maker - Granular system**  
Daily production up to 175 kg

|               |                      |
|---------------|----------------------|
| Hotel         | ████████████████████ |
| Restaurant    | ████████████████████ |
| Fast food     | ████████████████████ |
| Bar           | ████████████████████ |
| Disco         | ████████████████████ |
| Fish market   | ████████████████████ |
| Supermarket   | ████████████████████ |
| Medical & SPA | ████████████████████ |
| Industry      | ████████████████████ |

► Position n°



► Features & Plus

- Granular ice - 80-82% dry
- 1l (water) - 1kg (ice) - only Air cooled
- AISI 304 SS Scotch Brite finish
- Tropical class +43°C
- Adjustable Stainless Steel feet
- Removable and cleanable air filter
- AISI 304 SS evaporator
- Air or water cooling system
- Easy cleanable internal rounded surfaces
- HCFC-Free insulated storage
- Dust-proof water basin
- RoHS Free
- Disappearing insulated door
- Electromechanical operation
- ON-OFF rocker switch
- Automatic water charge
- Standard and special voltages
- HFC Free



AISI 304 SS Scotch Brite finish



Removable and cleanable air filter



AISI 304 SS evaporator



Dust-proof water basin

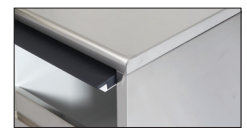

Disappearing insulated door

► Prod. 24h

| Air temp. | Water temp. |       | Kg    | Lbs |      |
|-----------|-------------|-------|-------|-----|------|
|           | 10° C       | 50° F |       |     | 7° C |
| 21° C     | 70° F       | 15° C | 60° F | 153 | 337  |

*Your professional partner*

► Certifications available for this model





Ice Flakes

# GB 1555 HC



## Self-contained ice maker - Granular system Daily production up to 175 kg

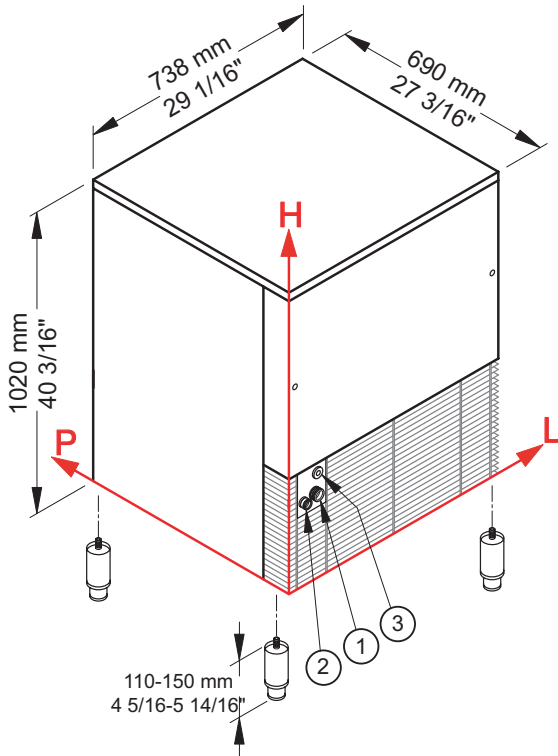

### ▶ Working conditions

- Location: **Indoor**

|                      | Min             | Max             |
|----------------------|-----------------|-----------------|
| Ambient temperature  | +10° C / +50° F | +43° C / 110° F |
| Water temperature    | +3° C / +37° F  | +32° C / +90° F |
| Voltage              | -10%            | +10%            |
| Water inlet pressure | 1bar (14 psi)   | 6bar (84 psi)   |

### ▶ Performances

|  | Air temperature | Water temperature | Water temperature |         |        |         |       |       |
|--|-----------------|-------------------|-------------------|---------|--------|---------|-------|-------|
|  |                 |                   | 7° C              | 45° F   | 15° C  | 60° F   | 21° C | 70° F |
|  | 10° C           | 175 kg            |                   |         |        |         |       |       |
|  | 50° F           | 386 lbs           |                   |         |        |         |       |       |
|  | 21° C           |                   | 153 kg            |         |        |         |       |       |
|  | 70° F           |                   |                   | 337 lbs |        |         |       |       |
|  | 32° C           |                   |                   |         | 133 kg |         |       |       |
|  | 90° F           |                   |                   |         |        | 293 lbs |       |       |

### ▶ Connections

All measures are referred to the rear bottom-left corner (L-H-Ø)

- ① Water in.: 104 mm / 4 2/16" - 247 mm / 9 12/16" - 3/4"      ② Water out.: 53 mm / 2 1/16" - 240 mm / 9 7/16" - 24 mm / 15/16"
- ③ Electrical connections: 92 mm / 3 10/16" - 319 mm / 12 9/16"

### ▶ Technical information

|                           |  |
|---------------------------|--|
| Production in 24h         | 153 kg / 337 lbs                       |
| Store capacity, up to     | 55 kg / 121 lbs                        |
| Cooling system            | A - W                                  |
| Refrigerant               | R290                                   |
| Standard voltage          | 220-240 V ~ 50 Hz                      |
| Average power consumption | 700 W                                  |
| Fuse                      | 10 A                                   |
| Electrical consumption    | 11 kWh/100kg                           |
| Finish                    | AISI 304 stainless steel, scotch brite |

|                            |                                |
|----------------------------|--------------------------------|
| Water consumption          | A: 1 l/kg - 12,0 gal/100 lbs   |
|                            | W: 7 l/kg - 84 gal/100 lbs     |
| Sizes (L-P-H mm)           | 738 - 690 - 1020               |
| (L-P-H in)                 | 29 1/16 - 27 3/16 - 40 3/16    |
| Sizes with pack (L-P-H mm) | 780 - 735 - 1185               |
| (L-P-H in)                 | 30 11/16 - 28 15/16 - 46 10/16 |
| Net weight                 | 94 kg / 207 lbs                |
| Gross weight               | 105 kg / 231 lbs               |

All the technical information must be considered at the following conditions:

- Sizes without feet
- Ambient temperature +21° C
- Water temperature +15° C
- Electrical consumption at +32° C (standard voltage)
- Average power consumption at +43° C (standard voltage)

Models and specifications are subject to change without notice

Rev. 01 - Issued April 2018