

Walk in climate chamber

# Walk in CLH 12



## Standard equipment:

- ✓ Perfectly meets requirements in Pharma industry
- ✓ Fully complies with Pharma regulations (ICH) Equipment
- ✓ Perfect test conditions are maintained in a wide range of temperature from 15°C to 40°C and relative humidity of 35% to 90% RH
- ✓ RAL 9016 coated exterior and interior
- ✓ Environmentally friendly refrigerant
- ✓ Solid door with replaceable seal
- ✓ Mechanical door locking system
- ✓ Automatic door closing system`
- ✓ Electronic temperature controller with digital display with the ability to change the temperature setting every 0.1k
- ✓ Capacitive touch screen controller
- ✓ Dynamic cooling and heating system
- ✓ Led lighting on ceiling
- ✓ Door locking system with security to prevent locking
- ✓ Panels insulated with CFC/HFC free insulation
- ✓ Skirting boards hygienically finished
- ✓ Active humidification by ultrasonic system

## Optional equipment:

- ✓ Extra temperature sensor
- ✓ External housing made of acid-resistant AISI 304 steel
- ✓ Internal housing made of acid-resistant AISI 304 steel
- ✓ ATEX
- ✓ Racks for in the chamber
- ✓ Fire safety possible 30 and 60 minutes, inside to outside, outside to inside and combined
- ✓ Window in door
- ✓ Water treatment for the ultrasonic unit of Hydrolab

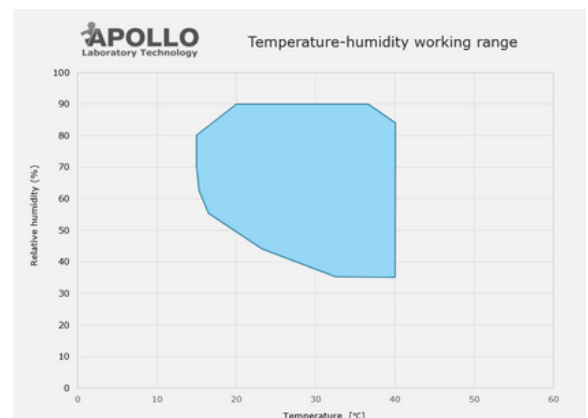

# Walk in CLH 12



7 inch touchscreen



Uniform temperature



Accurate humidity

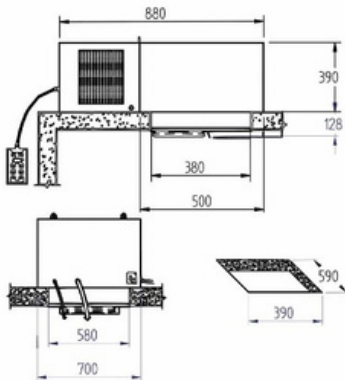

## Technical specifications:

	Width	Depth	Height
External dimensions [mm]	2410	2410 + 200 (ext. egt.)	2480 + 430 (cooler)
Internal dimensions [mm]	2250	2250	2300
Cooling unit type	AP-SP50M-2F		
Cooling type	Monoblock		
Gross capacity m <sup>3</sup>	11,64		
Net capacity	11,16		
Temperature range	15 - 40 [°C]		
Uniformity (°C)	+/- 1°C		
Fluctuation (°C)	+/- 0,5°C		
Humidity range	35 to 90% rH		
Uniformity (%)	+/- 2% rH		
Fluctuation (%)	+/- 1% rH		
Ambient conditions	10-38 [°C], 65% RV		
Refrigerant	R452A		
Power	840W cooler 4x45W internal fan, 4x150W		
Number of external doors	1		