

## Data sheet

## Tabletop Fume hood Compact Line DCL-1500 BB



### Standard equipment for fume hoods:

- structure entirely made of galvanized steel without the use of wood-based materials
- toughened glass window, lifted manually with counterweight, opened upwards with a lock on height 500 mm (max 810mm), the window has a system preventing the uncontrolled fall of the window
- energy-saving linear LED lighting separated from the fume hood's working chamber with a glass pane
- a double rear wall system with exhaust gaps in the upper and lower part ensuring the correct extraction of vapors that are lighter or heavier than air, without swirls and dead zones
- safety flap in the ceiling ensuring decompression in the event of uncontrolled pressure increase in the working chamber
- full monitoring set (Schneider brand) of air flow velocity in the fume cupboard window compliant with the PE-EN 14175 standard. : PN-EN 14175; PN-EN 14056; PN-EN 13150

**TECHNICAL DATA - DIMENSIONS**

**overall dims [mm]**

width A	1500
height B	1235-1320
depth C	700

**working space dims (mm)**

width D	1434
window width D1	1354
height E	1000
depth F	430

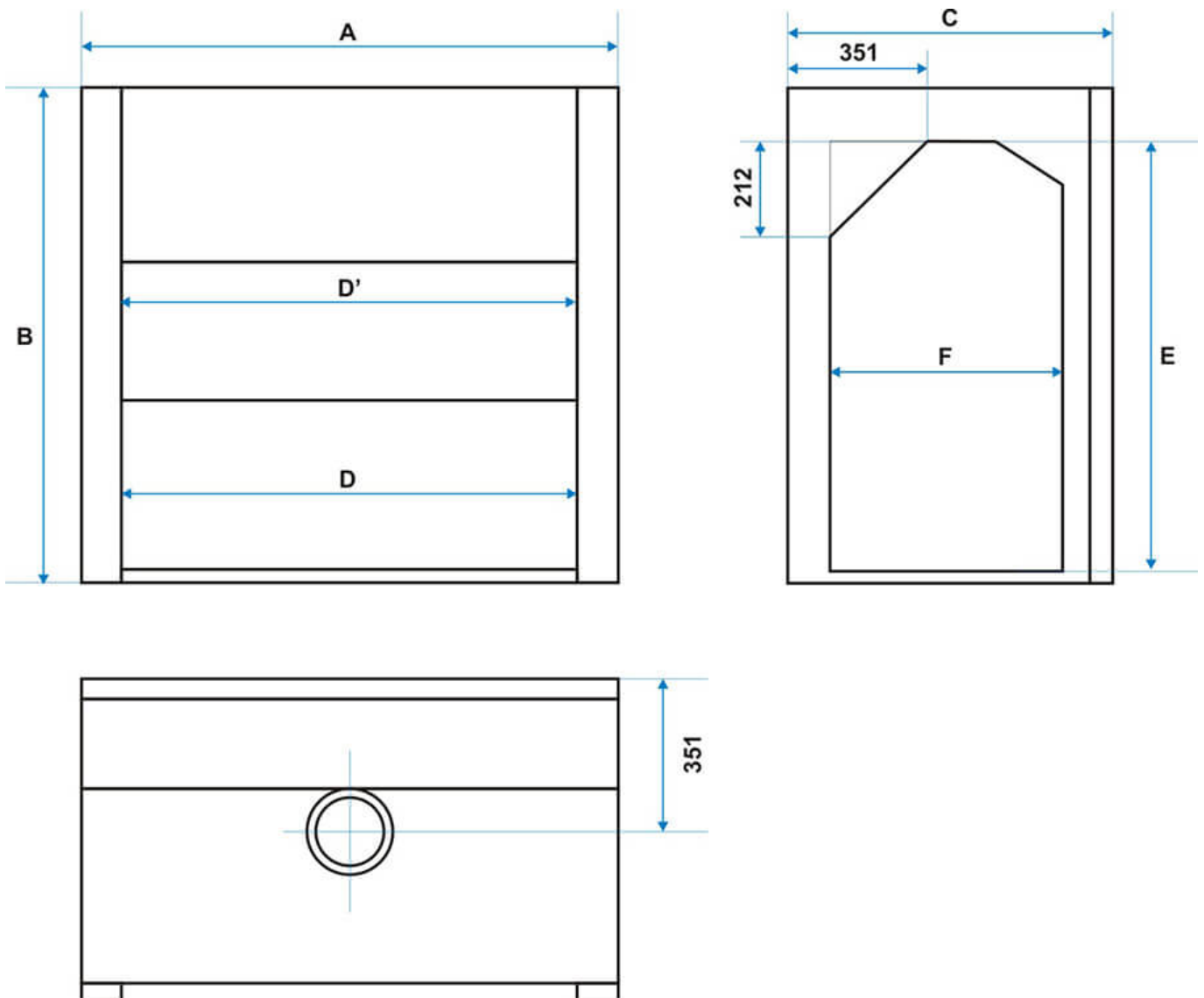

**TECHNICAL DATA**

recommended airflow [m <sup>3</sup> /h]	750 - 1200
required capacity of the ventilation system [m/s]	0,3 - 0,5
nominal power [W]	46
voltage**	230 VAC 50Hz
diameter of the air outlet stub [mm]	Ø 200
electrical insulation	class I
standard ventilation system	double rear wall
illumination installed outside the working chamber	LED, class A ++, through insulating glass / from operator panel
monitoring set	<i>standard:</i> - FM 550-A-0-E controller with a speed sensor AFS 100 in the fume hood window and the FA-0025-3 operator panel <i>option:</i> - ICM 500-F-EU controller with flow control - ICM 500-FP-EU controller with flow control and cooperation with BMS - other Schneider controllers available on request
raising the window	<i>standard:</i> - manual with counterweight (lock at a height of 500mm, maximum opening 810mm) <i>option:</i> - SC 500 - Auto Protect system - with foot switch - SC 500 - Auto Protect system - with panel switch
frame and housing material	The frame is made entirely of galvanized steel. External housing made of galvanized and painted with epoxy paint steel
working chamber wall finishing	galvanized sheet, powder coated with epoxy paint
worktop OPTION (available materials)	- Monolithic ceramics with marine edge - Phenolic resin, epoxy - Stainless steel AISI 304, 316
warranty	24 months
manufacturer	POL-EKO-APARATURA

**Other optional equipment:**

- main switch
- anti-shock switch
- safety switch
- 400VAC IP44 socket
- additional 230VAC IP44 sockets
- 230VAC sockets inside the working chamber IP44
- Manual Protect system - battery backup of the monitoring set
- power supply control of the socket with the option of timer setting
- additional gas taps
- metal cabinet key lock under the tabletop
- explosion-proof equipment EX
- side glazing
- truss made of acid-resistant steel, on the back wall of the manipulation chamber
- inspection openings
- flexible strip brush